

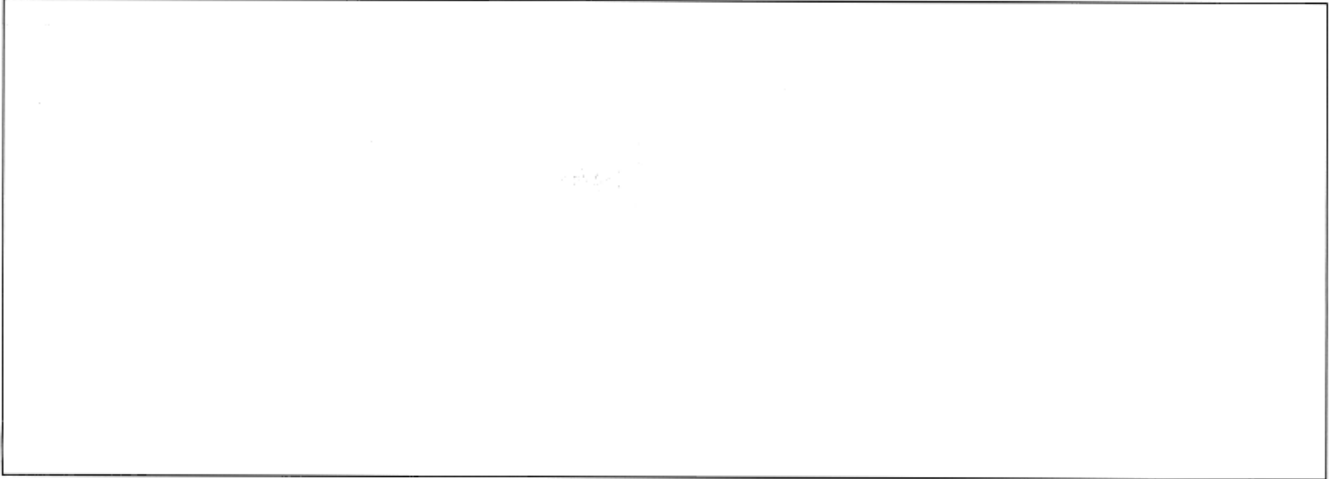

INSTRUCTION MANUAL
Includes
Single
and Dual
MVA/PC
Millivolt Alarm

No. 191-751-00 D

April 1974



1.1 SCOPE OF MANUAL

This manual contains a complete description, installation and operating instructions and maintenance instructions for the Plug-In DC Millivolt Alarm (MVA). To support any maintenance that might be required, this manual also includes a description of the theory of operation, schematic, printed circuit board assembly and list of materials with recommended spare parts indicated.

1.2 PURPOSE OF EQUIPMENT

The DC Millivolt Alarm (MVA) provides a signal that will operate an alarm system at a predetermined but adjustable value of DC voltage. The unit can also be supplied to operate the same or separate alarms at two different predetermined and adjustable values of DC voltage. As standard equipment, a lamp is supplied on the front panel for each trip to indicate visually the state (tripped or untripped) of the alarm.

1.3 GENERAL DESCRIPTION

The unit amplifies the applied input signal, adds the adjustable trip-point signal(s), and then uses the composite signal to drive the control amplifier(s). The signal for the external alarm system is produced by the closing or opening of a relay (or relays) controlled by the control amplifier(s). High stability is achieved through the use of feedback in each of the stages other than the control amplifier(s).

1.4 PHYSICAL DESCRIPTION

The Plug-In DC Millivolt Alarm (MVA) is available in two configurations, a single trip (upper trip point only) and a dual trip (both upper and lower trip points). Specific details for installing unit, both electrical connections and mechanical installation, are given in Section 2, Installation Information.

1.4.1 Single Trip

The single trip MVA consists of one printed circuit board containing all of the electronics.

1.4.2 Dual Trip

The dual trip MVA consists of two printed circuit boards, PCI and PC2. PC2 is connected to PCI with interconnect pins. PC2 contains the zero circuit electronics and PCI contains the remaining electronics.

1.5 SPECIFICATIONS

The specifications of the MVA are given in Table 1-1.

TABLE I-1. MVA SPECIFICATIONS

| | |
|-----------------------------------|--|
| <u>INPUT SPANS</u> | RANGE A: 0-20 millivolts RANGE B: 0-25 millivolts RANGE C: 0-100 millivolts RANGE D: 0-400 millivolts RANGE E: 0-1 volt RANGE F: 0-5 volts RANGE G: 0-10 volts |
| <u>INPUT IMPEDANCE</u> | 1 megohm minimum |
| <u>ZERO ADJUSTMENT</u> | ±10% of span (minimum) |
| <u>FRONT PANEL ADJUSTMENTS</u> | |
| <u>TRIP POINTS</u> | Multiturn front panel adjustment over a range of 0% to 110% of span |
| <u>INPUT ZERO</u> | ±10% of span (minimum) |
| <u>OUTPUT</u> | SPDT relay contacts 5A @ 117 VAC non-inductive |
| <u>PERFORMANCE</u> | |
| <u>REPEATABILITY</u> | Trip point repeats within ±0.1% full span |
| <u>DEADBAND</u> | 1% of span, standard |
| <u>AMBIENT TEMPERATURE RANGE</u> | 0°F to +150°F (-18°C to +65°C) |
| <u>AMBIENT TEMPERATURE EFFECT</u> | Less than ±0.01%/°F over above range |
| <u>RESPONSE</u> | 50 milliseconds for a step change of 1% of span beyond set points |
| <u>ISOLATION</u> | Input, output, and power input are isolated with no DC connections between them. |
| <u>POWER INPUT</u> | 24 VDC, 45 VDC, 65 VDC ±10% 5 watts maximum |
| <u>LINE VOLTAGE EFFECT</u> | ±0.005%/1% line change |

1.6 MODEL NUMBERING SYSTEM

Model Numbers describe an instrument's type, functional range, and features. If all accompanying documentation of a unit should be missing, one can still "translate" the Model Number back into a working description of the unit by using the information in this paragraph as a reference.

BASIC EXAMPLE

MVA/B/D-XIX3/24DC

MVA, 0-25 mV input full scale (from zero), dual trip output in XIX3 configuration, 24 VDC

BASIC INSTRUMENT TYPE

MVA indicates DC Voltage Alarm

INPUT RANGE

Range B: 0-25 millivolt span

OUTPUT RELAY MODES

First Letter: S indicates single trip (upper trip point only)

D indicates dual trip (both upper and lower trip points)

XIX3: XI indicates that upper trip-point relay is energized when input signal is below upper trip point (fail-safe mode); standard unless other option requested

X3 indicates that lower trip-point relay is energized when input signal is above lower trip point (fail-safe mode); standard unless other option requested

POWER INPUT

DC power, 24 VDC $\pm 10\%$ unless stated otherwise, e.g., 45 VDC,

Table 1-2 lists the option letters in the model numbers and explains their meanings.

TABLE 1-2. EXPLANATION OF OPTION LETTERS IN MODEL NUMBERS

| | |
|------|------------------------------------|
| -AD | ADJUSTABLE DEADBAND |
| -AR | FACTORY SET RESPONSE TIME DELAY |
| -DD | DOWNSCALE OPEN INPUT DRIVE |
| -FU | FUSE |
| -HS | HERMETICALLY SEALED RELAY OUTPUT |
| -IO | INDICATOR OUTPUT |
| -LSA | LOWER SPANS (2-5 mV) |
| -MR | MANUAL RESET - EXTERNAL PUSHBUTTON |
| -TT | PRECISION 10-TURN DIAL |
| -UD | UPSCALE OPEN INPUT DRIVE |

INSTALLATION INFORMATION

2.1 GENERAL INSTALLATION INFORMATION

Installation, in general, consists of adjustment (when required), mechanical mounting, and making the electrical connections to the unit. The following paragraphs describe the necessary procedures.

2.2 ADJUSTMENT

Units are checked for proper performance at the factory before they are shipped. However, unless adjustment was requested to a specific trip point (or pair of trip points), the unit should be adjusted by the user before the unit is placed in service.

NOTE

Adjustments should not be made in the field on units that are adjusted at the factory to a value (or values) specified in the purchase order. Units that are adjusted at the factory to customer's specifications have protective caps over the UPPER and LOWER trip point potentiometers; do NOT remove these caps.

A continuously adjustable DC voltage input signal source with a monitoring device for determining the input amplitude is required for adjustment. The input voltage monitoring device must have an accuracy within $\pm 0.05\%$ or better.

In the following procedure, it is assumed that the unit being adjusted is a dual-trip unit (with both upper and lower trip points) and with both upper and lower deadband adjustment options included. If the unit actually being adjusted does not have all these features, simply perform those steps that apply to that particular unit and omit the others.

NOTE

A single trip unit has all adjustments located on front panel. See printed circuit board assemblies for location of zero adjust and/or upper and lower deadband adjust if unit has -TT and/or -AD options.

To adjust a unit, proceed as follows:

- a. Connect unit and test equipment as shown in Figure 2-1. Initially turn the trip point, ZERO and DEADBAND potentiometers fully counterclockwise. If the trip point

INSTALLATION INFORMATION

a. (Cont'd)

potentiometers have 10-turn dials (TT option), carefully turn each dial to the desired setting instead of fully counterclockwise. It is assumed here that the LOWER trip point dial is set to a number greater than 0 and that the UPPER trip point dial is set to a number less than 100.

b. Apply power input to the unit and apply input signal voltage equal to the value of the lower trip point.

NOTE

Refer to paragraph 1.6 for information on how to use the model number to obtain the output configuration.

- c. Refer to Table 2-1 to determine which state of a lamp corresponds to a given state of the associated output section for a given configuration of that section. Turn the ZERO potentiometer clockwise until the lower section of the unit trips, and then turn the potentiometer counterclockwise until this section just untrips.
- d. Slowly turn the LOWER trip point potentiometer clockwise until the lower section of the unit just trips.

TABLE 2-1. OUTPUT STATES VS. OUTPUT CONFIGURATIONS

| OUTPUT | | ALARM STATE | | OUTPUT LAMP & RELAY STATE |
|---------------|----|-------------|-----------|---|
| CONFIGURATION | | TRIPPED | UNTRIPPED | |
| UPPER | X1 | TRIPPED | UNTRIPPED | LAMP "OFF" (K1 DEENERGIZED) LAMP "ON" (K1 ENERGIZED) |
| | X2 | TRIPPED | UNTRIPPED | LAMP "ON" (K1 ENERGIZED) LAMP "OFF" (K1 DEENERGIZED) |
| LOWER | X3 | TRIPPED | UNTRIPPED | LAMP "OFF" (K2 DEENERGIZED) LAMP "ON" (K2 ENERGIZED) |
| | X4 | TRIPPED | UNTRIPPED | LAMP "ON" (K2 ENERGIZED) LAMP "OFF" (K2 DEENERGIZED) |

INSTALLATION INFORMATION

- e. Check, and readjust, if necessary, the ZERO potentiometer by verifying that the lower section of the unit can be tripped and untripped with the LOWER trip point potentiometer. Leave this section of the unit in the tripped condition with the potentiometer adjusted almost, but not quite, fully counterclockwise. If the unit has the TT option, return the LOWER trip point dial to the desired setting, and make sure that this section of the unit is in the tripped condition.
- f. Turn the LOWER DEADBAND potentiometer fully clockwise. Increase the input voltage to the value of the upper limit of the lower deadband, and then slowly turn the LOWER DEADBAND potentiometer counterclockwise until the lower section of the unit returns to the untripped condition.
- g. Recheck the unit and return action of the lower section of the unit at input voltages equal to the lower trip voltage and the upper limit of the lower deadband to verify that the unit trips.
- h. Increase the input voltage to the value of the upper trip point.
- i. Turn the UPPER trip point potentiometer clockwise until this section of the unit is in the untripped condition, and then slowly turn the potentiometer counterclockwise until this section trips again. If the unit has the TT option, return the UPPER trip point dial to the desired setting, and make sure that this section of the unit is in the tripped condition.
- j. Turn the UPPER DEADBAND potentiometer fully clockwise. Decrease the input voltage to the value of the lower limit of the upper deadband, and then slowly turn the UPPER DEADBAND potentiometer counterclockwise until the upper section of the unit returns to the untripped condition.
- k. Recheck the trip and return action of the upper section of the unit at input voltages equal to the upper trip voltage and the lower limit of the upper deadband to verify that the unit trips at the desired upper trip point and exhibits the desired deadband.
- l. After step (k) has been successfully completed, remove the input signal and then turn off the power input to the unit.

INSTALLATION INFORMATION**2.3 MECHANICAL INSTALLATION**

Figure 2-2 shows the outline dimensions and other installation requirements. Be sure to observe the applicable special procedures and precautions given with the illustration. Although the units are designed to operate in free air at quite a high ambient temperature, if the unit is mounted in a rack, the rack should have adequate ventilation.

2.4 ELECTRICAL CONNECTIONS

No special wire or cable is required for signal connections. To avoid transients and stray pickup, it is recommended that twisted conductors be used where they are run close to other services (such as power wiring).

2.4.1 Unit Mounted in Moore Industries Inc. Rack

The terminals on the card rack are numbered to correspond with the pins of the connector in which the unit is inserted. The terminals to be used are indicated in Figure 2-3. Spade-lug connectors are recommended for all wire terminations. All terminals are supplied with 6-32 screws which will easily accept three spade-lug connectors.

2.4.2 Separately Mounted Unit

All connections are to be soldered directly to the mating connector. The pins of the connector to be used are indicated in Figure 2-3. The unit is designed to be operated from a DC power source. Refer to paragraph 1.6 for information on how to use the model number to determine the type of power required.

2.4.3 Power Connections To Moore Industries Inc. Rack

On DC powered racks, the DC terminal is connected to the + (positive) side of the power source and the DCC terminal is connected to the - (negative) side. The DC power source should be regulated to within $\pm 10\%$ of the nominal voltage and should be capable of delivering 3 watts.

On AC powered racks, 117 volts AC $\pm 10\%$, 50/60 Hz, 3 VA nominal power is required. The AC terminal should be connected to the ungrounded or "hot" side of the supply, if possible and the ACC terminal is connected to the common or neutral side. The GND terminal is the mechanical case connection.

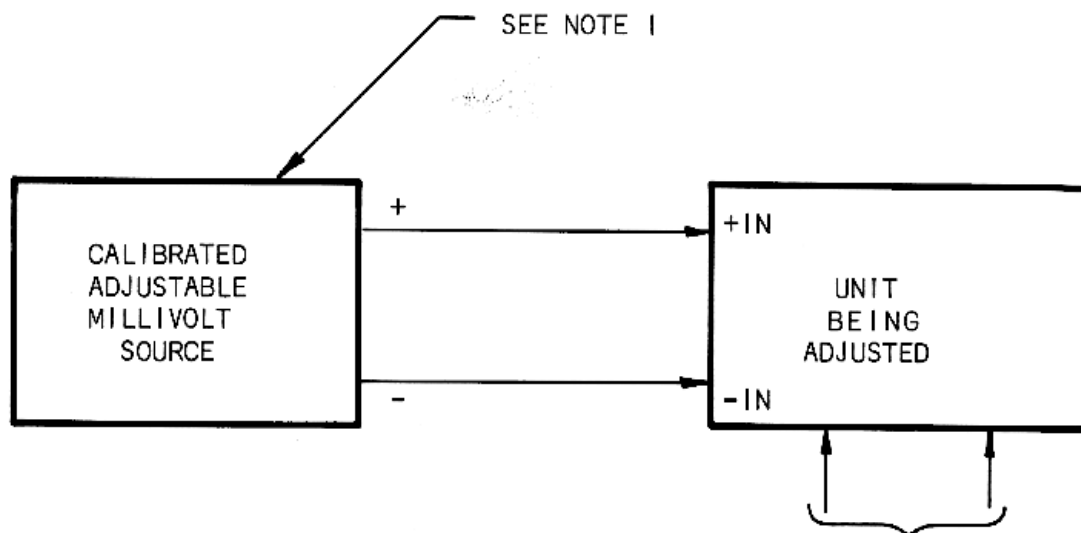

NOTES:

1. INPUT VOLTMETER MUST BE ACCURATE TO WITHIN $\pm 0.05\%$

Figure 2-1. Test Equipment Setup for Adjustment of Unit

SECTION 2

INSTALLATION INFORMATION

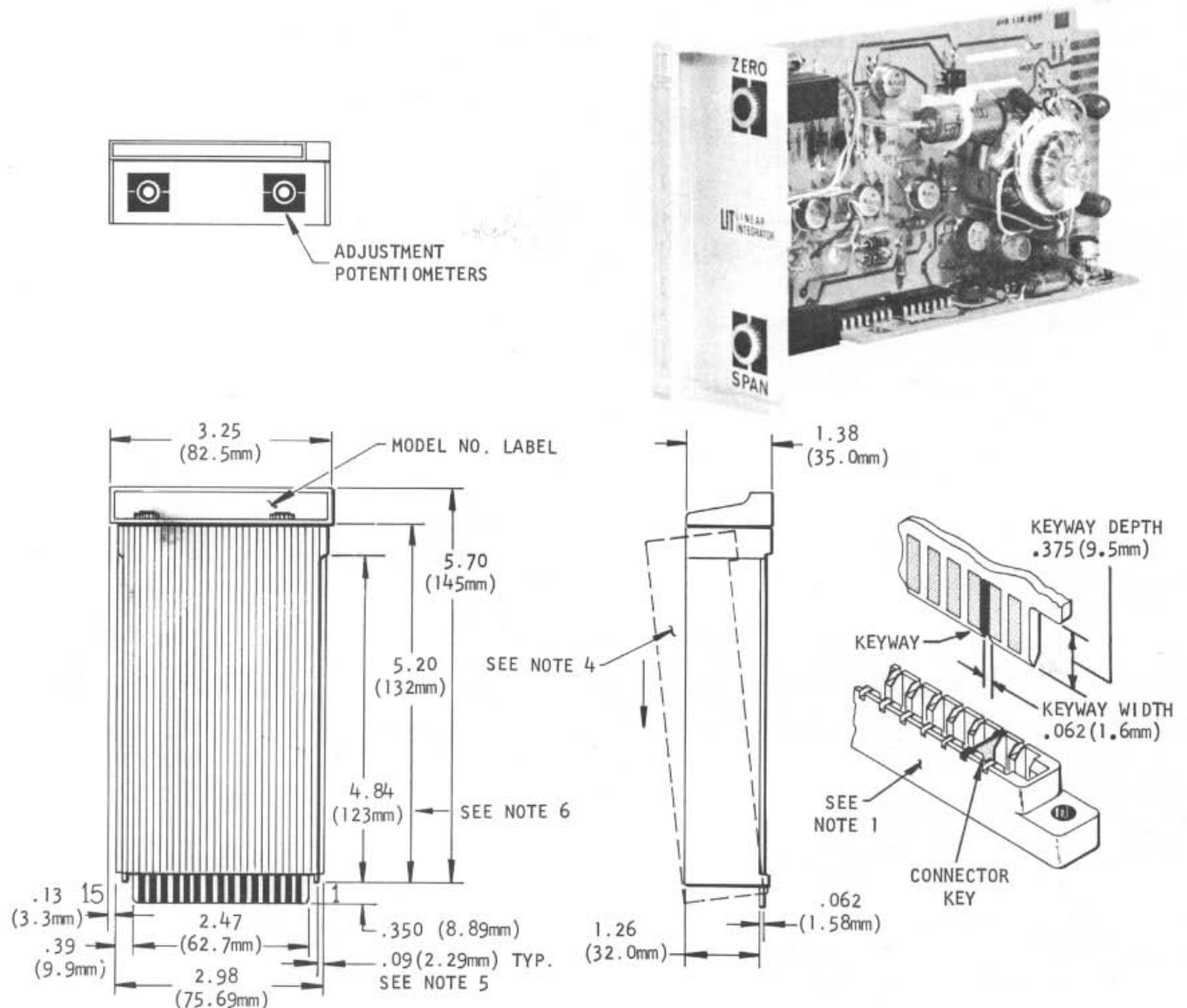

NOTES:

1. Connectors used must have contacts on .156 (3,96mm) centers, with contacts for both surfaces of board (recommended type: Viking part no. 2VK155/1-2).
2. Maximum card insertion depth in connector is .350 (8,89mm).
3. Minimum width of connector insertion slot is 2.470 (62,70mm).
4. Removable plastic safety cover, 2.800 (71,12mm) wide. To remove safety cover, spread forward locking feet and lift front end approximately 1/4 inch; then slide cover to rear to disengage from card. **CAUTION** - DO NOT LIFT FRONT HIGHER THAN 1/4" OR TABS AT CONTACT END WILL BREAK.
5. Maximum card edge-guide insertion depth is .09 (2,29mm). Guides must be non-conductive.
6. Card edge-guides cannot extend beyond here.
7. Card extender part no. 350-513-00 is available for testing transmitter while in operating position

Figure 2-2. Outline and Installation

SECTION 2

INSTALLATION INFORMATION

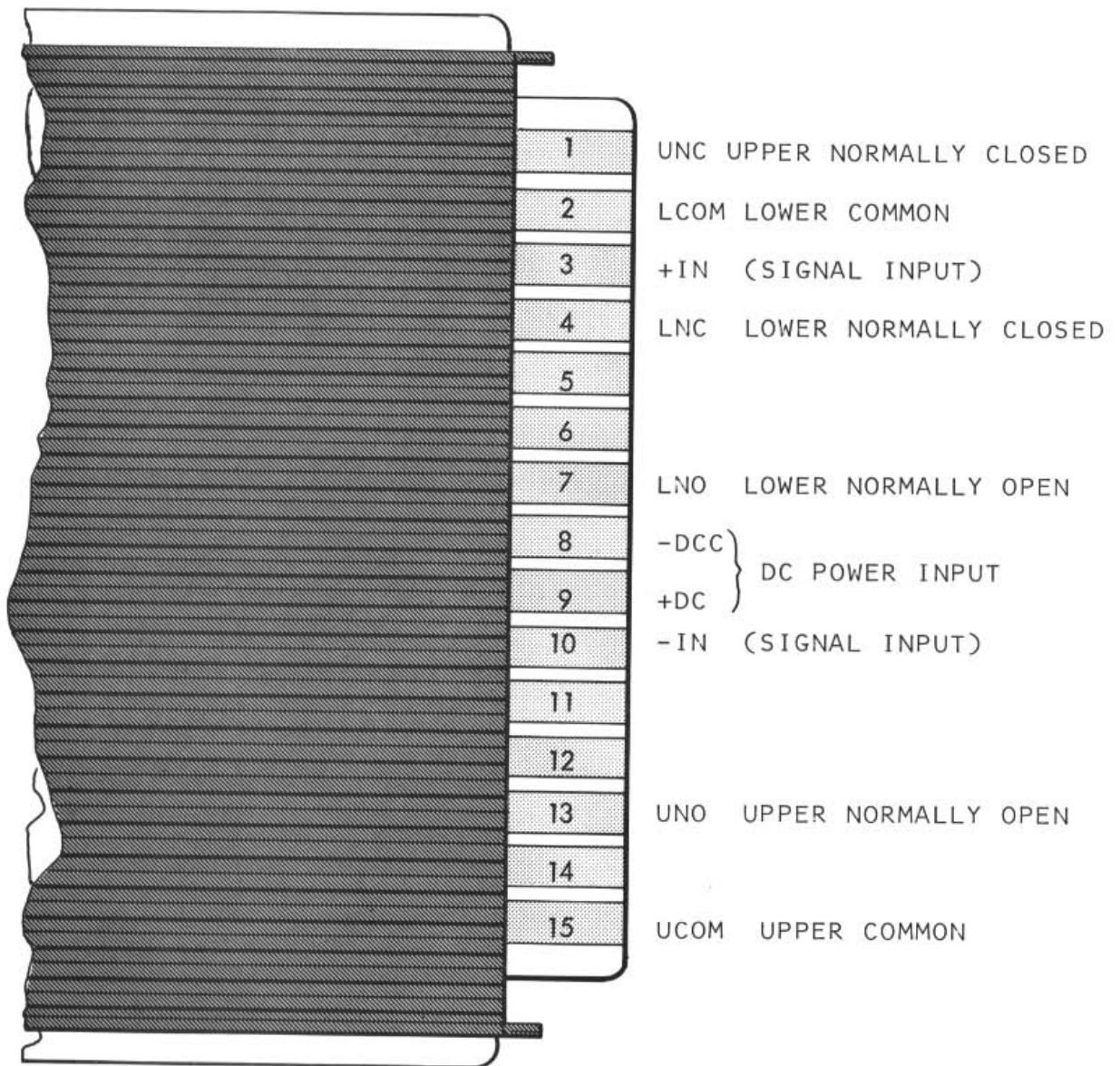

Figure 2-3. Electrical Connections For Plug-In Units

3.1 OPERATING PROCEDURE

Once adjusted and installed, the unit may be operated unattended. A lamp associated with each output relay is included on the unit as a standard feature. These lamps inform the operator when alarm condition has occurred. Note carefully, however, that an illuminated lamp does not necessarily indicate an alarm condition, since a relay may be energized either with a normal (non-alarm) input signal (X1 and X3 output configurations, non-fail-safe operation). There are no other indicators on the unit. Because the circuit uses highly reliable solid-state components, except for relays, the unit should operate virtually maintenance-free for a long period of time. However, if a malfunction should occur, refer to Section 5 for maintenance information.

A unit may become warm during operation, especially where the ambient temperature is rather high. This is perfectly normal and should not be a cause for concern unless a malfunction is also observed.

THEORY OF OPERATION**4.1 INTRODUCTION**

This section describes the theory of operation of the unit. The description is based on a unit that has dual trips in the XI, X3 configuration (see main schematic diagram) and two deadband adjustments. If the particular unit supplied does not have all these features, simply disregard those elements of the schematic and the accompanying text that do not apply.

4.2 CIRCUIT DESCRIPTION

The main schematic diagram of the unit is near the end of this manual. Except where otherwise indicated, refer to this diagram when reading the following paragraphs.

4.2.1 Power-Inverter Circuit

The DC applied to the unit is converted to a square wave of approximately 3 KHz by Q1, Q2 and the primaries of T1, functioning as a DC-to-AC inverter. Filter LI-C3 prevents the 3 KHz signal from getting back into the external DC source. CR8 provides protection against damage from inadvertent application of DC of incorrect polarity. In a unit with the -FU option, fuse F1 protects the inverter from damage that could result from an overload. The square-wave output from center-tapped secondary 8-13 is rectified by CR16 and CR17 to produce positive DC output, and by CR14 and CR15 to produce negative DC output. These outputs are filtered by C11, C12, C13 and C14, and regulated by R39, CR12, R40 and CR13 to produce outputs of +12 and -12 volts as operating voltages for the unit. A somewhat higher positive voltage (point C) is utilized for operating the output relay(s) and lamp(s). The other secondary (16-17) of T1 provides AC input to the circuit that develops the DC source for the zero-adjust circuit.

4.2.2 Description Of Input Buffer Circuit

The input buffer consists of IC2 and associated components. The stage serves to isolate the input-signal source from later stages in the unit, so adjustment in the value of trip point(s) will not affect the input signal. A small voltage, adjustable with the ZERO potentiometer, is added to the input signal to modify the live zero and allow the lower section of the unit to trip at the desired lower trip point. The circuit that supplies this voltage consists of CR201 and associated filter capacitor, resistors, and zener diodes, plus a bridge circuit that includes an adjustable element. The AC voltage supplied to points D and E is applied through R201 to half-wave rectifier CR201. C201 filters the pulsating output from CR201 and the resulting DC voltage is applied through R202 to zener diode CR202 for initial regulation and then through R203 to zener diode CR203 for final regulation to 6.2 volts. This voltage is then applied to the bridge circuit that includes the ZERO potentiometer as the adjustable element.

R205, R206, R208 and the ZERO potentiometer from the bridge circuit and the output from CR203 is applied between the junction of R205 and R206 and the junction of R208 and terminal 3 of the ZERO potentiometer. The wiper of the

THEORY OF OPERATION

ZERO potentiometer is connected to common and is at one corner of the bridge output. Thus, moving the wiper of the ZERO potentiometer changes the potential of the -IN terminal (and, therefore, the +IN terminal) with respect to common. The ZERO potentiometer is adjusted so the composite signal drives IC2 to make the lower section of the unit trip with the input voltage equal to the lower trip point and with the LOWER trip point potentiometer not turned fully counterclockwise, or, in a unit with the TT option, with the LOWER trip point dial at the desired setting.

The composite signal at the +IN terminal is applied through R29 and R19 to the non-inverting input (pin 3) of IC2, which is used as a buffer with sufficient gain and a low output impedance to reliably drive the following stages. C2, C9 and R19, together with IC2, form an active low-pass filter with a very sharp cutoff characteristic to remove any noise or other high-frequency components from the signal applied to IC2. R16 and R26 provide feedback to the inverting input and thus determine the gain of IC2. R16 is selected to establish the gain of IC2 according to the range of the applied input signal. The ± 12 -volt outputs from the power supply are used to power IC2.

4.2.3 Description Of Upper Comparator Circuit

The upper comparator consists of IC3 and associated components. The output from IC2 is applied through the UPPER TRIP PT. ADJ to the inverting input (pin 2) of IC3. With no input signal applied a portion of the negative voltage developed by zener diode CR3 is supplied to pin 2 of IC3. This negative voltage at pin 2 causes the output of IC3 (pin 6) to be positive, consequently CR10 and CR11 are both reverse-biased. When the input signal is applied and exceeds the voltage set by the UPPER LEVEL TRIP PT. ADJ. the output of IC3 becomes negative forward biasing CR11 and CR10. With CR11 forward feedback is applied to IC3 and with CR10 forward biased a negative signal is applied to the relay driver. The level of the signal fed back to the non-inverting input (pin 3) of IC3 is determined by the setting of the UPPER LEVEL DEADBAND ADJ.

When the applied input again becomes normal (i.e., the output from IC2 falls below the upper trip point), the output of IC3 will not immediately return to its original positive state. Instead, because feedback through CR11 keeps pin 3 less positive than before, the output from IC3 remains negative until the driving signal from IC2 decreases to a value below that of the signal at pin 3. When this occurs, the output of IC3 abruptly returns to its original positive state and CR11 is no longer forward-biased. Because the level of signal at pin 3 shifts when CR11 is conducting compared with when it is not conducting, the value of input signal at which IC2 returns to positive output is somewhat lower than that at which the change occurred from positive to negative output (upper trip point exceeded). The difference between these two values is called the upper deadband, and it is determined by the adjustment of the UPPER DEADBAND potentiometer.

THEORY OF OPERATION

4.2.4 Description Of Lower Comparator Circuit

The lower comparator circuit consists of IC1 and associated components. The circuit description of the lower comparator circuit is the same as the upper comparator circuit described in paragraph 4.2.4.

4.2.5 Description Of Upper Relay Driver

The upper relay driver consists of Q5, Q6, and associated components. Whether the output relay is energized or deenergized below the trip point is determined by the connection of the relay status selection jumper. When JX1 is connected and the input signal to IC2 is below the upper level trip point, the output of IC2 is positive. With the output of IC3 positive, Q5 is conducting, thus KI is energized. As the input signal increases above the trip point Q5 is turned off and KI is deenergized. When JX2 is connected and the input signal of IC2 is below the upper level trip point, the output of IC3 is positive. With the output of IC3 positive, Q5 is conducting and Q6 is turned off, causing relay KI to be deenergized. As the input increases above the trip point, Q5 is turned off and Q6 is turned on, causing KI to be energized.

4.2.6 Description Of Lower Relay Driver

The lower relay driver consists of Q3, Q4 and associated components. The description of the lower relay driver is the same as the upper relay driver described in paragraph 4.2.6.

MAINTENANCE INFORMATION

5.1 INTRODUCTION

This section contains information on maintenance of the unit. General troubleshooting procedures are given, using conventional signal-tracing techniques. Precautions and special techniques used to replace components are also described.

5.2 PERIODIC MAINTENANCE

It is suggested that the adjustment of the unit be checked approximately every 6 months as described in Section 2. No other periodic maintenance is required.

5.3 CORRECTIVE MAINTENANCE

The following paragraphs provide information on corrective maintenance of the unit. Corrective maintenance should be carried out only by qualified personnel who have read and thoroughly understand the description of circuit operation given in Section 4.

5.3.1 Disassembly

To troubleshoot the unit, it is first necessary to disassemble it so the circuit board is exposed. These steps are described in the following paragraphs. In all cases, disconnect the input signal and turn off the power input before disassembling the unit.

5.3.1.1 Disassembly Of A Plug-In Unit

To remove the cover of a plug-in unit proceed as follows:

- a. Gently spread the forward locking feet and lift the front of the cover NO MORE THAN 1/4 INCH. Excessive force applied to the cover may break the rear retaining clips.
- b. With the front of the cover raised, slide the cover to the rear to disengage it from the plug-in card.

If it is desired to test a plug-in unit in the operating position, a circuit-board extender (Part 350-513-00 or equivalent) is required to bring the unit forward so the components on the circuit board are accessible for troubleshooting.

MAINTENANCE INFORMATION**5.3.2 Troubleshooting**

The schematic diagram(s) includes flagged numbers or letters at various points in the circuit. Table 5-1 gives the voltages and waveforms at these points for specified input-signal conditions. The assembly drawing(s) shows the physical locations of the parts on the circuit board. Bear in mind that the circuit board is protected with a moisture-resistant coating. Therefore it may be necessary to use a needle-point probe and exert a fair amount of pressure to break through the coating when it is desired to observe the signal or voltage at a specific point. When connecting a probe to a component on the circuit board, exercise care to make sure the probe does not short-circuit to an adjacent component. In general, troubleshooting is carried out by tracing the signal with an oscilloscope and referring to the schematic diagram(s) to determine what component might be causing an observed abnormal indication. If the original symptom was a complete failure of the unit to operate, the most logical components to suspect are those associated with the power supply in the unit. If the unit tripped (or failed to trip) with an applied input that should have produced the opposite condition, check the output from the power supply and, if these are normal, apply a standard input signal and trace the resulting signal through the unit.

5.3.3 Component Replacement Techniques And General Precautions

Replace all defective components with identical parts. Refer to the assembly drawing(s) and list(s) of materials for a list of replacement parts. The letter S and a number, all enclosed in a circle, appear after the description of certain parts in the list of materials. The number indicates the number of spares recommended to be kept on hand for that part, per unit, for up to ten units of the same type. For more than ten units, a spares complement of 10% on the indicated parts should be used.

Most parts used in the unit are quite small and are located in a confined area. Therefore, small hand tools are a necessity when servicing the unit. The following is a summary of the general techniques and precautions that should be observed to prevent damage to components in the unit:

- a. Use a transformer-operated low-voltage soldering iron with a grounded tip and rated at not more than 50 watts. A temperature-controlled tip is desirable.
- b. Use extreme care when unsoldering the leads to any component. Do not keep the soldering iron on a point for more than a few seconds at a time. Use a suction-type solder-removing tool (solder sucker) as an aid in unsoldering transistors and integrated circuits. The protective coating on the unit may be removed with trichlorethane or equivalent. Be sure adequate ventilation is provided when using this or any other chemical.

MAINTENANCE INFORMATION

NOTE

Unused connections on integrated circuits are left unsoldered to aid in removal. Refer to the assembly drawing for more complete information.

- c. Do not excessively bend or twist the leads of small components; they break easily.
- d. Before removing a component, observe the lead configuration. Be sure that the lead configuration of the replacement is the same as that of the original.
- e. Remove all flux from soldered joints with trichlorethane or equivalent.

NOTE

Units that were adjusted at the factory to customer's specifications have protective caps over the UPPER and LOWER trip point and ZERO potentiometers. These caps must be removed so the unit can be readjusted. LIFT, DO NOT TWIST, the caps off, using a screwdriver tip as a prying tool. Snap the caps back in place, WITHOUT TWISTING, when readjustment has been completed.

- f. Test, and if necessary, adjust the unit for proper operation, as follows:
 - (1) Connect the unit and test equipment as shown in Figure 2-1, but temporarily omit the input voltage source. Turn the trip point, ZERO, and DEADBAND potentiometers fully counterclockwise.
 - (2) Apply power input to the unit. Jumper +IN to common and adjust R38 for 0V at pin 6 of IC2. Disconnect jumper and apply input voltage source.
 - (3) If the unit does not have the TT option, continue by connecting the voltage source and performing step (b) and the following steps in paragraph 2.2. If the unit does have the TT option, continue with step (4) in the present paragraph.

MAINTENANCE INFORMATION

NOTE

Adjust the sealed potentiometers only if required to obtain the specified results.

- (4) Set the LOWER trip point dial to exactly 0. From a higher value, decrease the input voltage to exactly the 0% value. If the lower section of the unit is now in the untripped condition, adjust ZERO potentiometer when lower just trips.

NOTE

If the factory set resistor (R208) does not allow for sufficient adjustment of the ZERO potentiometer proceed as follows:

- (1) Replace R208. Install Bourns switching device on R208.
- (2) Set ZERO potentiometer to mid-range. Apply 0% input to the Input terminals.
- (3) Set Bourns switching device for the exact resistance to read 0V at pin 6 of IC2.
- (4) When the exact value of resistance has been determined, note the resistance of R208 selected by the switching device, then apply solder to the appropriate pads and their adjacent collectors.
- (5) Slowly increase the input voltage until the lower section of the unit just untrips and note the value of input voltage at which this occurs. Slowly decrease the input voltage at which this occurs. Slowly decrease the input voltage until the lower section of the unit just trips again, which should occur at 0% input. The difference in values of input voltage at which the lower section of the unit untrips and trips must not be more than 1% of the input span of the unit. In addition, trip and untrip input voltages must each repeat within $\pm 0.1\%$ of this same input voltage span when the procedure is repeated. Make sure that the lower section of the unit is in the tripped condition with 0% input voltage applied.

MAINTENANCE INFORMATION

- (6) Turn the LOWER DEADBAND potentiometer fully clockwise, and then slowly increase the input voltage until the lower section of the unit just untrips. The voltage at which this occurs must be higher than the trip value in step (5) by not less than 10% of the input span of the unit.
- (7) If necessary, repeat steps (4), (5), and (6) to make sure that all specified conditions are met.
- (8) Set LOWER trip point dial to 100. From a higher value, decrease the input voltage to exactly the 100% value. If the lower section of the unit is now in the untripped condition, adjust R8 until the lower section just trips.
- (9) Set the UPPER trip point dial to 100. From a lower value, increase the input voltage to exactly the 100% value. If the upper section of the unit is not tripped, adjust R37 until the upper section just trips.
- (10) Slowly decrease the input voltage until the upper section of the unit just untrips, and note the value of input voltage at which this occurs. Slowly increase the input voltage until the upper section of the unit just trips again, which should occur at 100% input. The difference in values of input voltage at which the upper section of the unit untrips and trips must not be more than 1% of the input span of the unit. In addition, trip and untrip input voltages must each repeat within $\pm 0.1\%$ of this same input voltage span when the procedure is repeated. Make sure that the upper section of the unit is in the tripped condition with 100% of the input voltage applied.
- (11) Turn the UPPER DEADBAND potentiometer fully clockwise, and then slowly decrease the input voltage until the upper section of the unit just untrips. The voltage at which this occurs must be lower than the trip value in Step (10) by not less than 10% of the input span of the unit.
- (12) If necessary, repeat steps (9), (10), and (11) to make sure that all specified conditions are met. When this is assured, carefully reseal the shaft of R8 and R37 with red Glyptal or equivalent, if required.

MAINTENANCE INFORMATION

- g. When proper operation of the unit has been verified as in step (f) readjust the unit by the procedure given in Section 2. When the performance of the unit is known to be satisfactory, apply clear acrylic to reseal the unit where required.
- h. Check that all leads are clear of the board edge before reinstalling the safety cover.

TABLE 5-1. WAVE FORMS AND AMPLITUDE

| TEST POINT | WAVE FORM AND AMPLITUDE OR VOLTAGE LEVEL |
|------------|--|
| 1 | <p>0 to 1V DEPENDING ON INPUT -----0V</p> |
| 2,5* | <p>+10V INPUT LESS THAN SET POINT -----0 -10V INPUT GREATER THAN SET POINT</p> |
| 3,6* | <p>+6V(X2), +20V (X1) (X4)*, (X3)* -----0</p> |
| 4,7* | <p>+20V (X2), (X4)* -----0</p> |

| DC OPERATED UNITS | | | | |
|-------------------|------------------------------|-------------------------------------|-------|-------|
| TEST POINT | WAVE FORM | POWER INPUT AND WAVE FORM AMPLITUDE | | |
| | | 24VDC | 45VDC | 65VDC |
| A | <p>A ----- 333µs</p> | 48V | 90V | 130V |

* WAVE FORMS 5, 6, AND 7 ARE FOR DUAL TRIP UNITS ONLY.

| REV | DESCRIPTION | DATE | BY | APPR |
|-----|-------------|------|----|------|
| | | | | |

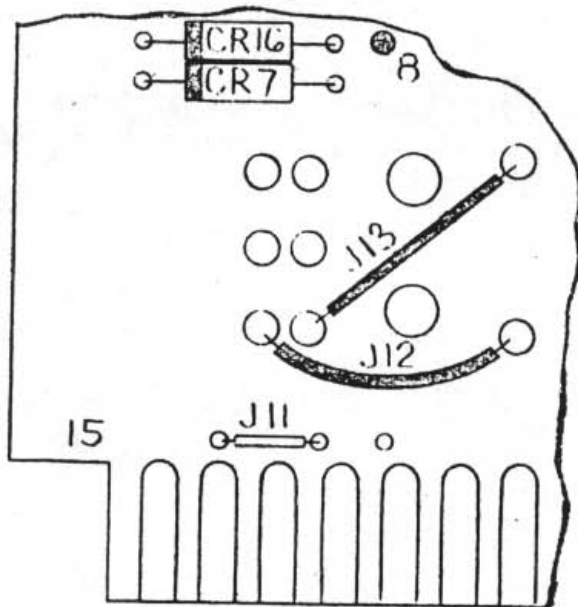

MOUNTING OF J12 & J13

NOTES: UNLESS OTHERWISE SPECIFIED

| | | | | |
|---|--|--|---|---------------|
| TOLS UNLESS NOTED: .X = ±.10 .XX = ±.030 .XXX = ±.010 ANGLES = ± 30° HOLES = +.002 - .001 | DRAWN T. HART 2-27-76 | MOORE INDUSTRIES INC. SEPULVEDA ■ CALIF. | | |
| | CHECKED <i>[Signature]</i> 3/6/76 | | P.C. BOARD ASSEMBLY PLUG-IN MVA SINGLE | |
| DO NOT SCALE DRAWING | PROJ. ENGR. <i>[Signature]</i> 3/6/76 | DWG. NO. 191-551-00 | | REV. H |
| SCALE: 2/1 | CUSTOMR. | | | |

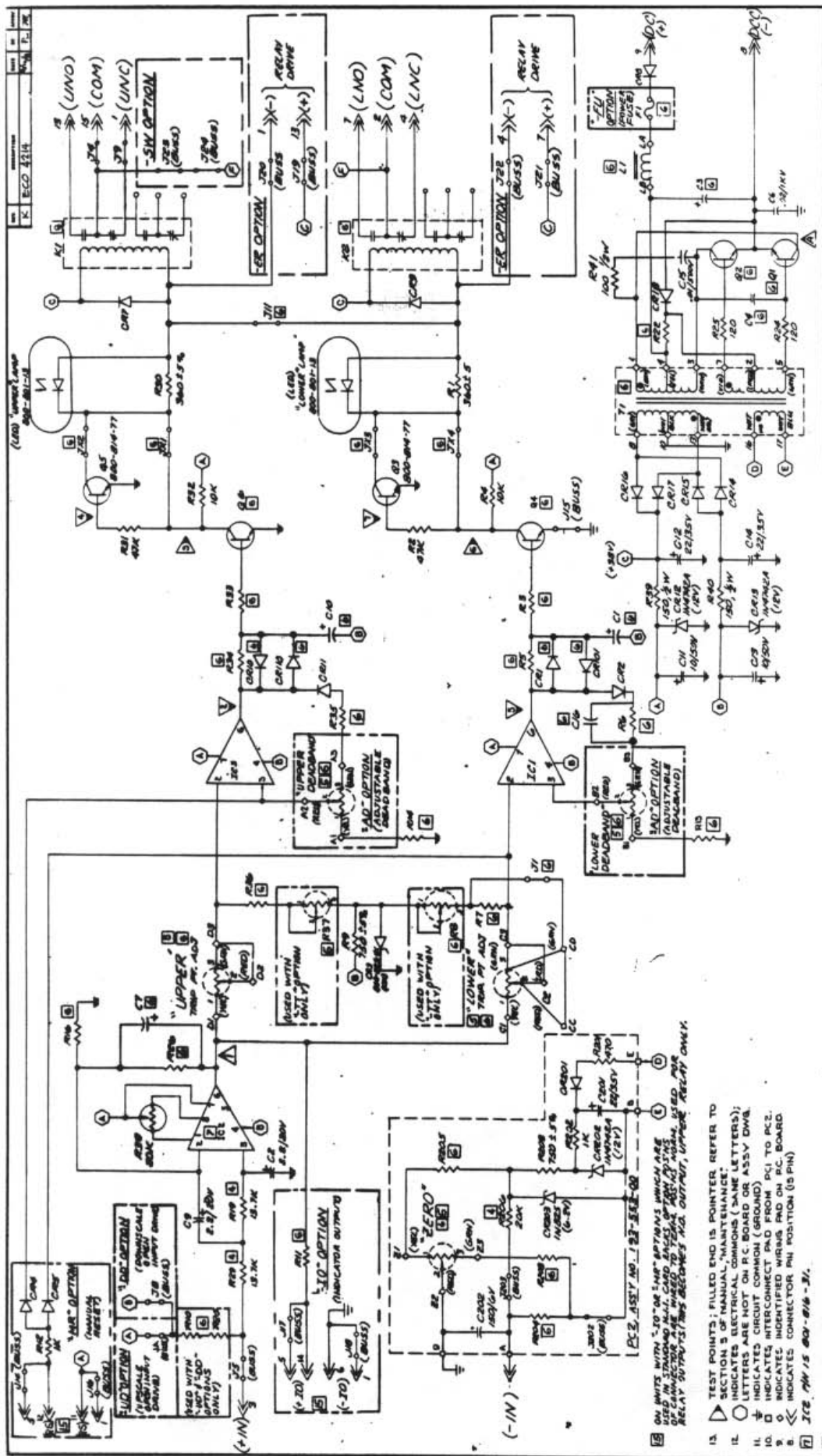

| | |
|---|--|
| <p>191-52-00</p> <p>191-52-00</p> | |
| <p>SCHEMATIC PLUG-IN MVA, DUAL TRIP</p> | |
| <p>191-52-00</p> | |
| <p>191-452-00K</p> | |

1. TEST POINTS: FILLED END IS POINTER REFER TO SECTION 5 ELECTRICAL MAINTENANCE.
 2. LETTERS ARE NOT ON P.C. BOARD OR ASSY DWG.
 3. INDICATES CIRCUIT COMMON (GROUND) OR ASSY DWG.
 4. INDICATES INTERCONNECT PAD FROM P.C. TO P.C.
 5. INDICATES IDENTIFIED WIRING PAD ON P.C. BOARD.
 6. INDICATES CONNECTOR PIN POSITION (IS PIN)
 7. ICE #115 800-816-31.
 8. SEE LIST OF MATERIALS FOR VALUE AND PART NUMBER, AND/OR USE.
 9. ITEMS NOT MOUNTED ON P.C. BOARD.
 10. METAL FILM RESISTOR, 1%.
 11. ALL POTENTIOMETERS INCREASE C.W. FROM 1 TO 8.
 12. ALL INTD. WTS. ARE M.I.L. PN 800-852-31; DIODES ARE 800-4148 (1); RESISTORS ARE CARB. CONR. A W100K.
 13. RESISTANCE IN OHMS; CAPACITANCE IN MICROFARADS.
 14. MICRO. VALUES OTHERWISE SPECIFIED

| REV. | DESCRIPTION | DATE | BY | APPROV. |
|------|-------------|---------|-----|---------|
| D | ECO 1407 | 3/20/75 | JVN | JMR |

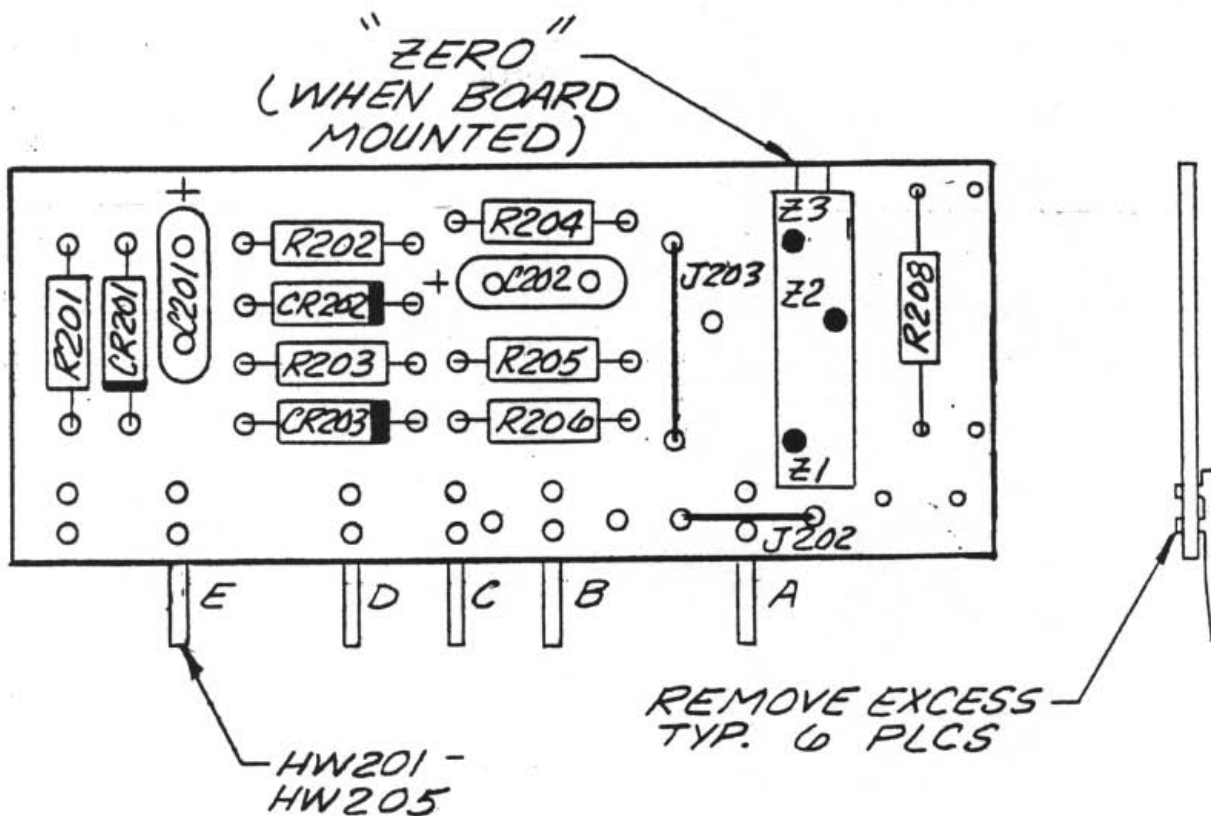

3. NEXT ASS'Y - 191-552-00.

2. ALL LEADS AND TERMINALS MUST BE SOLDERED TO PADS.

1. JUMPERS ARE 22AWG BUSS, TEFLON SLEEVED AS REQ'D.

NOTES: UNLESS OTHERWISE SPECIFIED

| | | | | |
|---|----------------------|--------------------|---------|--|
| DIMENSIONS ARE IN INCHES UNLESS NOTED OTHERWISE | DRAWN | <i>[Signature]</i> | 4/13/75 | MOORE INDUSTRIES INC. VAN NUYS ■ CA. |
| | CHECKED | <i>[Signature]</i> | | |
| TOLS. UNLESS NOTED: .X = ±.10 .XX = ±.030 .XXX = ±.010 ANGLES = ± 30' | PROJ. ENGR. | <i>[Signature]</i> | 4/18/75 | P.C BOARD ASS'Y PLUG-IN MVA PC2 - DUAL TRIP |
| | DO NOT SCALE DRAWING | | | |
| SCALE: 2:1 | CUSTOMER | | | DWG. NO. 191-553-00 |
| | | | | REV. D |

RETURN PROCEDURES

To return equipment to Moore Industries for repair, follow these four steps:

1. Call Moore Industries and request a Returned Material Authorization (RMA) number.

Warranty Repair –

If you are unsure if your unit is still under warranty, we can use the unit's serial number to verify the warranty status for you over the phone. Be sure to include the RMA number on all documentation.

Non-Warranty Repair –

If your unit is out of warranty, be prepared to give us a Purchase Order number when you call. In most cases, we will be able to quote you the repair costs at that time. The repair price you are quoted will be a "Not To Exceed" price, which means that the actual repair costs may be less than the quote. Be sure to include the RMA number on all documentation.

2. Provide us with the following documentation:
 - a) A note listing the symptoms that indicate the unit needs repair
 - b) Complete shipping information for return of the equipment after repair
 - c) The name and phone number of the person to contact if questions arise at the factory
3. Use sufficient packing material and carefully pack the equipment in a sturdy shipping container.
4. Ship the equipment to the Moore Industries location nearest you.

The returned equipment will be inspected and tested at the factory. A Moore Industries representative will contact the person designated on your documentation if more information is needed. The repaired equipment, or its replacement, will be returned to you in accordance with the shipping instructions furnished in your documentation.

WARRANTY DISCLAIMER

THE COMPANY MAKES NO EXPRESS, IMPLIED OR STATUTORY WARRANTIES (INCLUDING ANY WARRANTY OF MERCHANTABILITY OR OF FITNESS FOR A PARTICULAR PURPOSE) WITH RESPECT TO ANY GOODS OR SERVICES SOLD BY THE COMPANY. THE COMPANY DISCLAIMS ALL WARRANTIES ARISING FROM ANY COURSE OF DEALING OR TRADE USAGE, AND ANY BUYER OF GOODS OR SERVICES FROM THE COMPANY ACKNOWLEDGES THAT THERE ARE NO WARRANTIES IMPLIED BY CUSTOM OR USAGE IN THE TRADE OF THE BUYER AND OF THE COMPANY, AND THAT ANY PRIOR DEALINGS OF THE BUYER WITH THE COMPANY DO NOT IMPLY THAT THE COMPANY WARRANTS THE GOODS OR SERVICES IN ANY WAY.

ANY BUYER OF GOODS OR SERVICES FROM THE COMPANY AGREES WITH THE COMPANY THAT THE SOLE AND EXCLUSIVE REMEDIES FOR BREACH OF ANY WARRANTY CONCERNING THE GOODS OR SERVICES SHALL BE FOR THE COMPANY, AT ITS OPTION, TO REPAIR OR REPLACE THE GOODS OR SERVICES OR REFUND THE PURCHASE PRICE. THE COMPANY SHALL IN NO EVENT BE LIABLE FOR ANY CONSEQUENTIAL OR INCIDENTAL DAMAGES EVEN IF THE COMPANY FAILS IN ANY ATTEMPT TO REMEDY DEFECTS IN THE GOODS OR SERVICES, BUT IN SUCH CASE THE BUYER SHALL BE ENTITLED TO NO MORE THAN A REFUND OF ALL MONIES PAID TO THE COMPANY BY THE BUYER FOR PURCHASE OF THE GOODS OR SERVICES.

ANY CAUSE OF ACTION FOR BREACH OF ANY WARRANTY BY THE COMPANY SHALL BE BARRED UNLESS THE COMPANY RECEIVES FROM THE BUYER A WRITTEN NOTICE OF THE ALLEGED DEFECT OR BREACH WITHIN TEN DAYS FROM THE EARLIEST DATE ON WHICH THE BUYER COULD REASONABLY HAVE DISCOVERED THE ALLEGED DEFECT OR BREACH, AND NO ACTION FOR THE BREACH OF ANY WARRANTY SHALL BE COMMENCED BY THE BUYER ANY LATER THAN TWELVE MONTHS FROM THE EARLIEST DATE ON WHICH THE BUYER COULD REASONABLY HAVE DISCOVERED THE ALLEGED DEFECT OR BREACH.

RETURN POLICY

For a period of thirty-six (36) months from the date of shipment, and under normal conditions of use and service, Moore Industries ("The Company") will at its option replace, repair or refund the purchase price for any of its manufactured products found, upon return to the Company (transportation charges prepaid and otherwise in accordance with the return procedures established by The Company), to be defective in material or workmanship. This policy extends to the original Buyer only and not to Buyer's customers or the users of Buyer's products, unless Buyer is an engineering contractor in which case the policy shall extend to Buyer's immediate customer only. This policy shall not apply if the product has been subject to alteration, misuse, accident, neglect or improper application, installation, or operation. THE COMPANY SHALL IN NO EVENT BE LIABLE FOR ANY INCIDENTAL OR CONSEQUENTIAL DAMAGES.



WORLDWIDE • www.miinet.com

| | | |
|--|--|--|
| United States • info@miinet.com Tel: (818) 894-7111 • FAX: (818) 891-2816 | Belgium • info@mooreind.be Tel: 03/448.10.18 • FAX: 03/440.17.97 | China • sales@mooreind.sh.cn Tel: 86-21-62491499 • FAX: 86-21-62490635 |
| Australia • sales@mooreind.com.au Tel: (02) 8536-7200 • FAX: (02) 9525-7296 | The Netherlands • sales@mooreind.nl Tel: (0)344-617971 • FAX: (0)344-615920 | United Kingdom • sales@mooreind.com Tel: 01293 514488 • FAX: 01293 536852 |